

# BFAT-S

The BFAT-S is a BFAT with Ag plated terminals









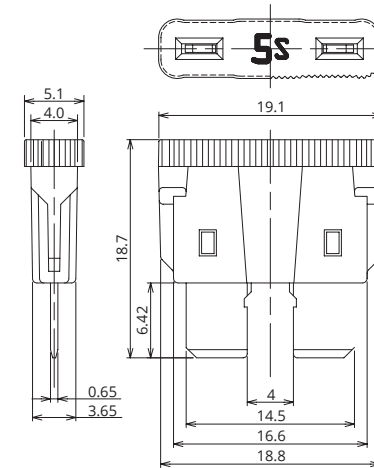

## General Specification

Rated Voltage	DC32V
Breaking Capacity	1000A
Operation Temperature	-40°C~80°C
Standard	ISO8820-3
Country of Origin	Japan
Plating	Ag Plating
Standard Packaging	12,000
Insertion Force	—
Extraction Force	—
Recommended Torque	—

## Dimensions



## Product Lineup

Ampere Rating(A)	Part Number	Housing Colors	Resistance Value	Voltage Drop
5	1131	Tan 	17.5 mΩ	121 mV
7.5	1132	Brown 	11.0 mΩ	112 mV
10	1133	Red 	8.12 mΩ	116 mV
15	1134	Blue 	5.08 mΩ	105 mV
20	1135	Yellow 	3.58 mΩ	99 mV
25	1136	Natural 	2.76 mΩ	96 mV
30	1137	Green 	2.20 mΩ	92 mV
40	1138	Orange 	1.48 mΩ	95 mV

## Time-Current Characteristic

% of Ampere Rating(A)	Operating Time	
	Min	Max
110%	100hrs.	—
135%	0.75sec.	600sec.
160%	0.25sec.	50sec.
200%	0.15sec.	5sec.
350%	0.04sec.	0.5sec.
600%	0.02sec.	0.1sec.

\*The fuse characteristic may change depending on the conditions of use.

## Time-Current Characteristic Chart

