

CH 10 gPV - Fuse-links

General characteristics UL file: E347771

Rated voltage	1000V d.c. L/R=2ms
Breaking capacity	10kA d.c. / 30kA d.c.
Standards	UL 2579, UL 248-1
Application	For protection of photovoltaic modules.



CH 10x38 gPV

Size	I_n [A]	Code No. "standard contacts" 10kA UL	Code No. "standard contacts" 30kA IEC	Code No. "type SU contacts" 30kA IEC	Pre-arcing Joule integral [A ² s] L/R=2ms	Operating Joule integral [A ² s] L/R=2ms	Power dissipation [0,7 x I _n] ² P _d [W]	Power dissipation [I _n] ² P _d [W]	Weight [g]	Packaging [pcs]
10 x 38	0,5		002625134	002625131	0,016	0,068	0,2	0,52	10/12	10/500 SU:10/380
	1		002625138	002625129	1,5	3	0,42	1,0		
	2	002625101	002625065	002625115	1,7	2,3	0,47	1,12		
	3	002625100	002625067	002625113	2,8	5,4	0,65	1,6		
	3,5	002625135	002625068	002625127	2,5	7	0,57	1,4		
	4	002625102	002625069	002625116	3,9	11,7	0,52	1,25		
	5	002625111	002625070	002625124	8	21	0,63	1,49		
	6	002625103	002625071	002625117	10,6	34,6	0,73	1,75		
	7	002625110	002625072	002625114	16	60	0,74	1,74		
	8	002625104	002625073	002625118	17	65	0,8	1,9		
	10	002625105	002625075	002625119	8,3	33	0,97	2,4		
	12	002625106	002625077	002625120	22	73	0,8	1,9		
	13	002625137	002625078	002625128	21	70	1,0	2,3		
	14	002625136	002625079	002625126	28	92	1,3	3,0		
	15	002625112	002625080	002625125	49	145	1,0	2,2		
	16	002625107	002625081	002625121	48	147	1,1	2,6		
	20	002625108	002625085	002625122	86	245	1,3	3,2		
	25*		002625109	002625123	125	289	1,65	4,1		
25		002625139	002625140	110	470	1,65	4,1			

* 900V d.c.

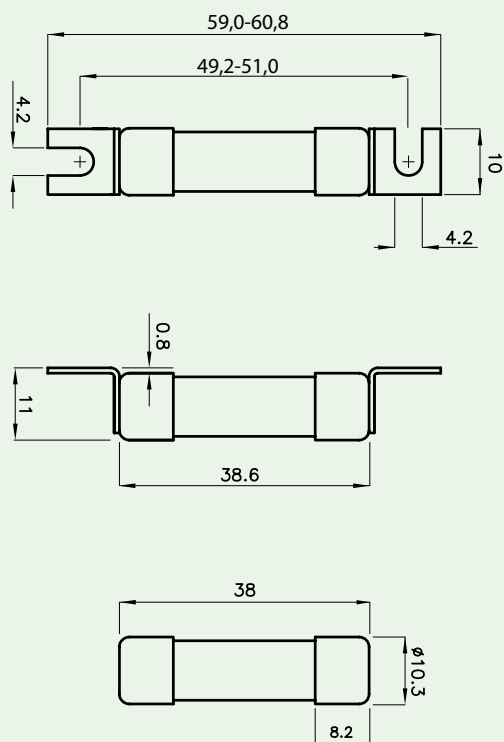

Standard Contacts



Type SU Contacts

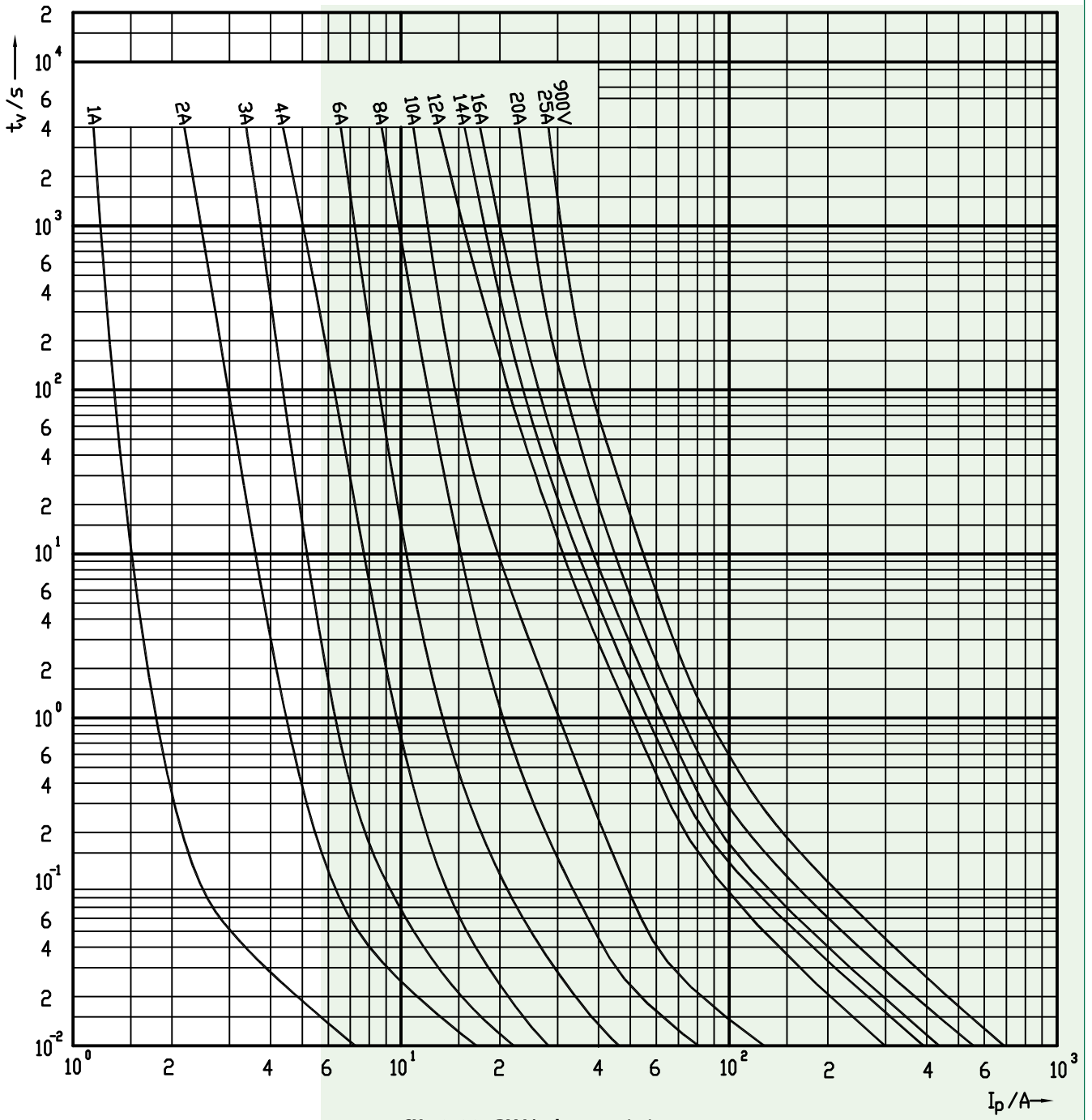

CH 10x38 gPV I/t characteristics

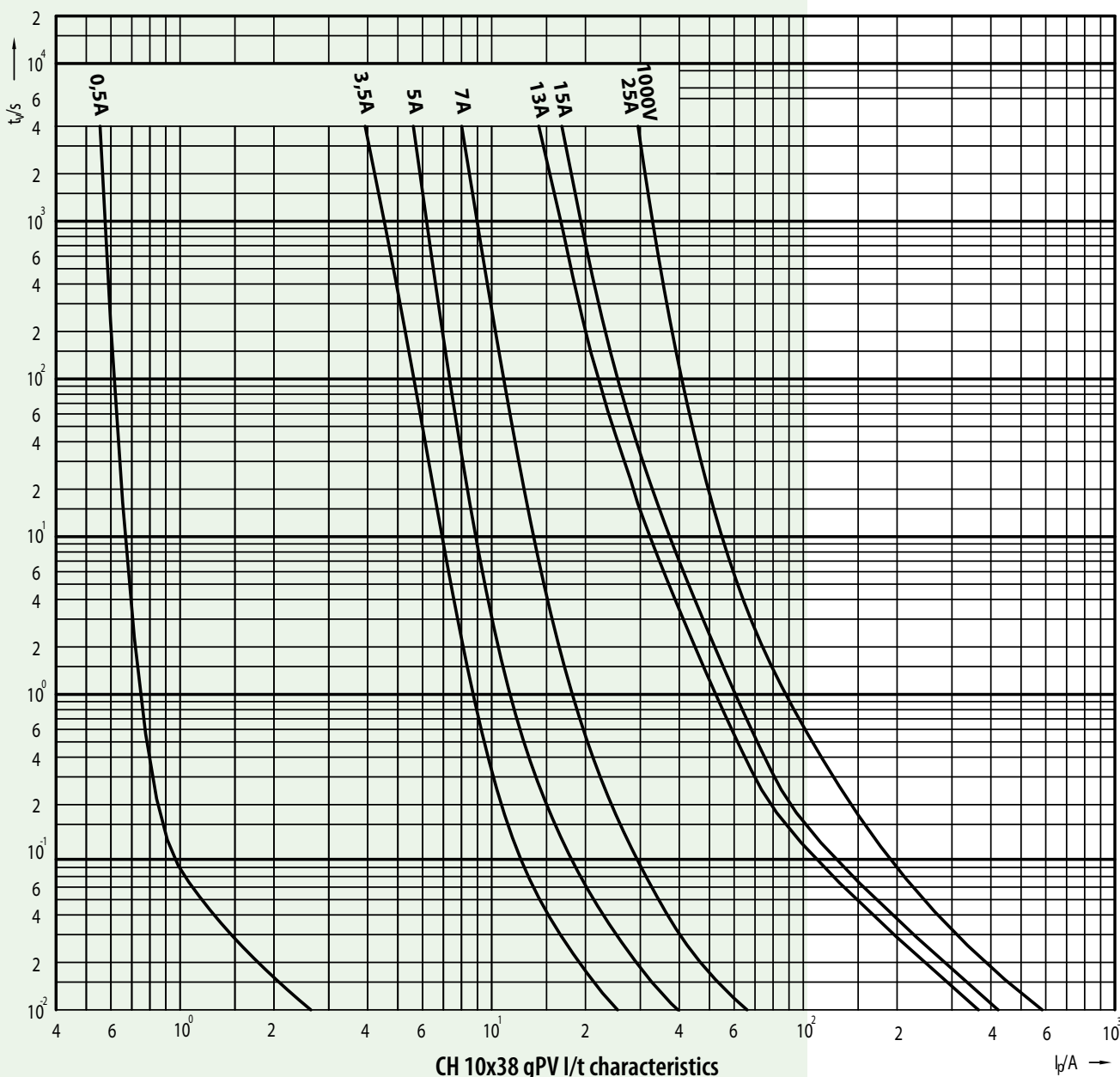

Tamb (°C)	A1
-20	1,196
-10	1,153
0	1,109
10	1,063
20	1,015
30	0,964
40	0,911
50	0,854
60	0,794
70	0,728
80	0,656

