

FP2207R

High frequency, high current power inductors



Product features

- High current carrying capacity
- Low core loss
- Magnetically shielded
- 22.5 mm x 8.2 mm footprint surface mount-package in a 7.25 mm height
- Moisture Sensitivity Level: 1
- Ferrite core material

Applications

- Multi-phase and Vcore regulators
- Voltage Regulator Modules (VRMs) and high-power density VRMs
 - Server and desktop
 - Central processing unit (CPU)
 - Graphics processing unit (GPU)
 - Application specific integrated circuit (ASIC)
- Data networking and storage systems
- Graphics cards and battery power systems
- Point-of-Load modules (POL)

Environmental data

- Storage temperature range (Component): -55 °C to +125 °C
- Operating temperature range: -55 °C to +125 °C (ambient plus self-temperature rise)
- Solder reflow temperature: J-STD-020 (latest revision) compliant
- Halogen free, lead free, RoHS compliant



Product Specifications

Part Number ⁸	OCL ¹ (nH) ±10%	FLL ² (nH) minimum	I _{rms} ³ (A)	I _{sat} 1 ⁴ (A)	I _{sat} 2 ⁵ (A)	I _{sat} 3 ⁶ (A)	DCR (mΩ) ±15% @ 20 °C	K-factor ⁷
FP2207R1-R230-R	230	196	50	75	77	72	0.47	182.5

R1 Version

1. Open Circuit Inductance (OCL) Test Parameters: 1.0 MHz, 0.1 Vrms, 0.0 Adc, +25 °C
2. Full Load Inductance (FLL) Test Parameters: 1.0 MHz, 0.1 Vrms, I_{sat}1, +25 °C
3. I_{rms}: DC current for an approximate temperature rise of 40 °C without core loss. Derating is necessary for AC currents. PCB layout, trace thickness and width, air-flow, and proximity of other heat generating components will affect the temperature rise. It is recommended that the temperature of the part not exceed +125 °C under worst case operating conditions verified in the end application.
4. I_{sat}1: Peak current for approximately 5% rolloff @ +25 °C
5. I_{sat}2: Peak current for approximately 20% rolloff @ +100 °C
6. I_{sat}3: Peak current for approximately 20% rolloff @ +125 °C

7. K-factor: Used to determine B_{pp} for core loss (see graph).
B_{p-p} = K * L * ΔI * 10⁻³ B_{pp}: (Gauss), K: (K-factor from table),
L: (Inductance in nH), ΔI (Peak to peak ripple current in Amps).
8. Part Number Definition: FP2207Rx-Rxxx-R
FP2207R= Product code and size
x= Version indicator
Rxxx= Inductance value in μH, R= decimal point
-R suffix = RoHS compliant
Note: Hipot: 250 Vdc minimum for 2 seconds, 0.1 mA conductor to core

Dimensions (mm)

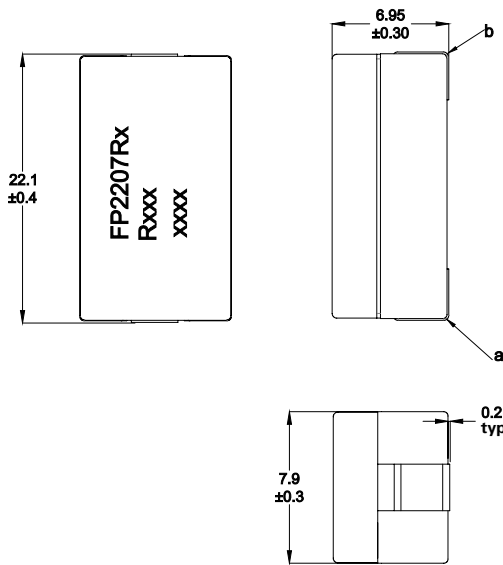

Recommended Pad Layout

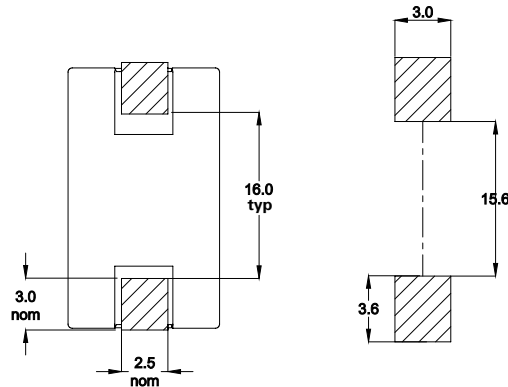

Schematic

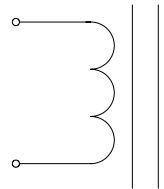

Part marking: FP2207Rx (x = Version indicator), Rxxx = Inductance value in uH, R= decimal point), xxxx=Lot code

Tolerances are ±0.15 unless stated otherwise

Pad layout tolerances are ±0.1 unless stated otherwise

Soldering surfaces to be coplanar within 0.1 millimeters

DCR measured from point "a" to point "b"

Secure Inductor to PCB using Circuit Bond LV (or equivalent) adhesive for mechanical stability to meet Vibration, Mechanical shock and shear force requirements.

Do not route traces or vias underneath the inductor

Packaging information (mm)

Supplied in tape and reel packaging , 500 parts per 13" diameter reel

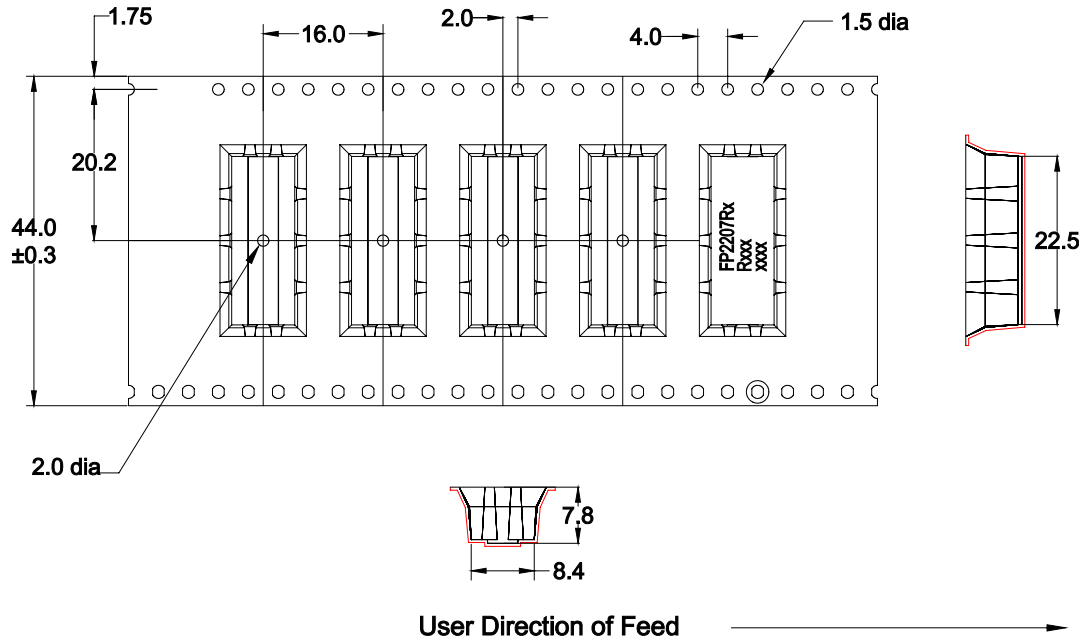

Temperature rise vs. total loss

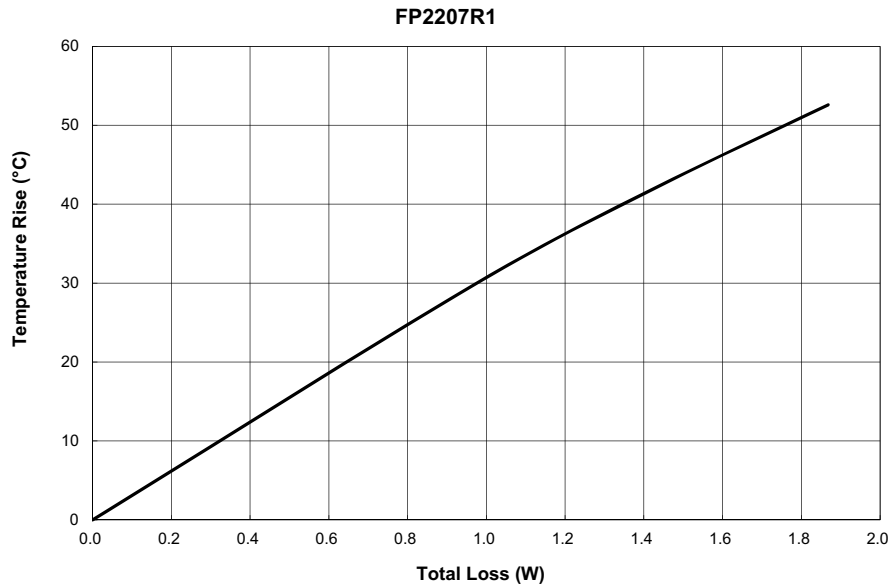

Core loss vs. B_{p-p}

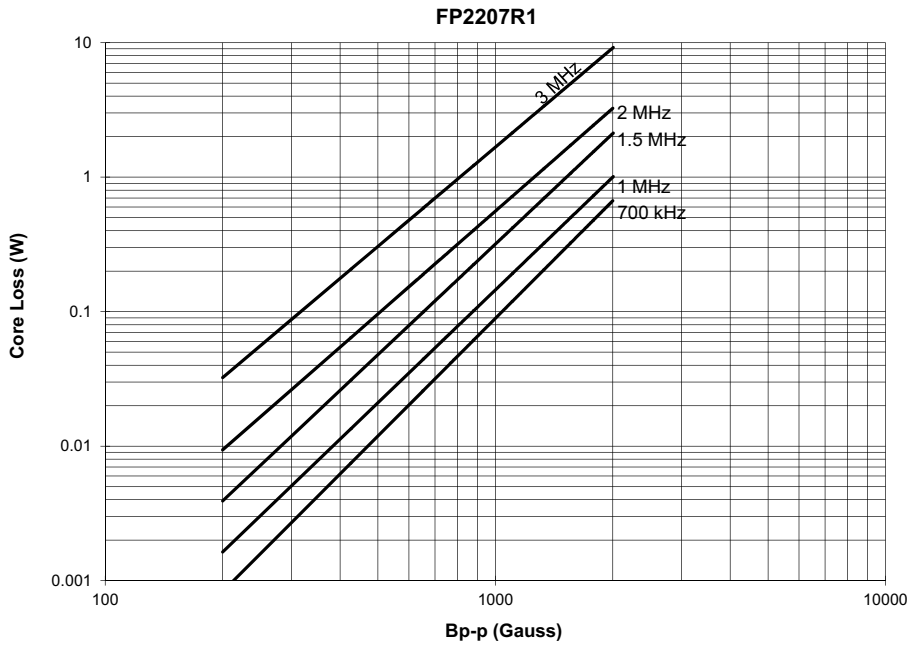

Inductance characteristics

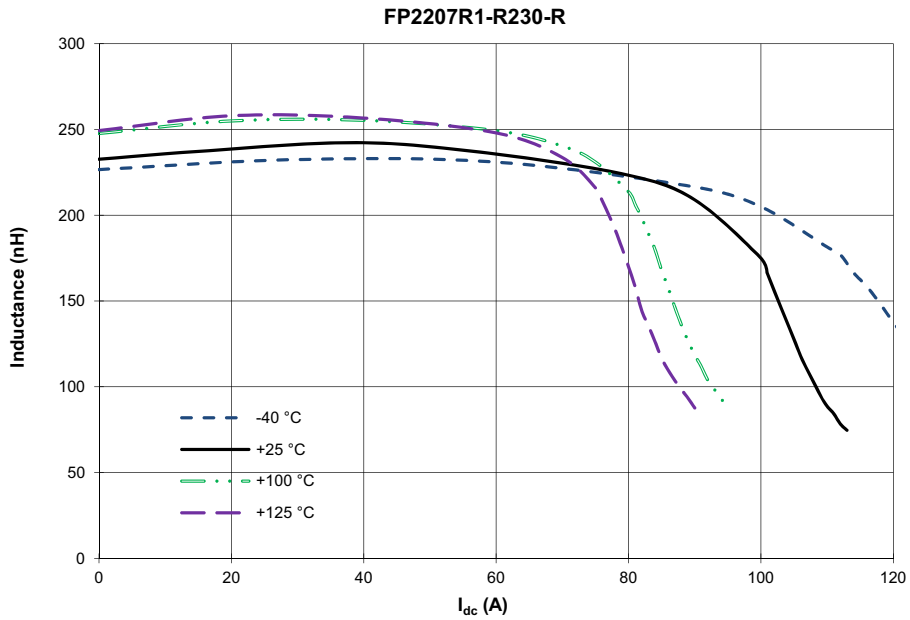

Solder reflow profile

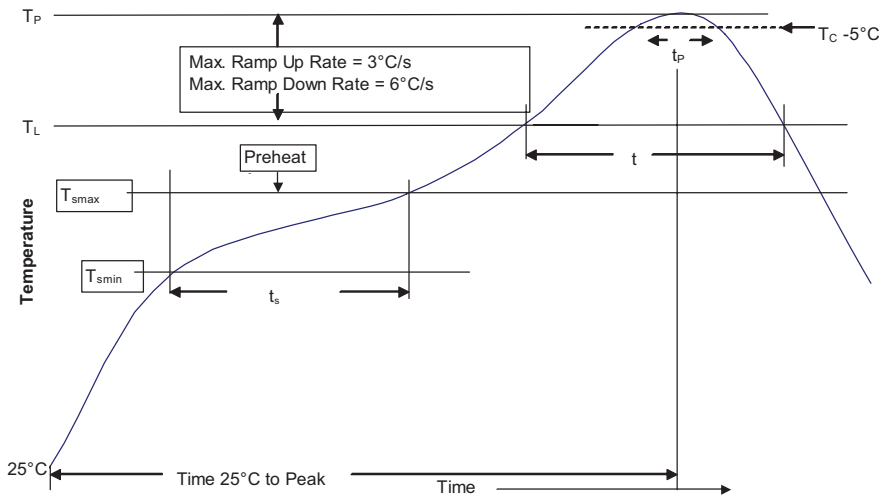

Table 1 - Standard SnPb Solder (T_c)

Package Thickness	Volume mm ³ <350	Volume mm ³ ≥350
<2.5mm)	235 °C	220 °C
≥2.5mm	220 °C	220 °C

Table 2 - Lead (Pb) Free Solder (T_c)

Package Thickness	Volume mm ³ <350	Volume mm ³ 350 - 2000	Volume mm ³ >2000
<1.6mm	260 °C	260 °C	260 °C
1.6 - 2.5mm	260 °C	250 °C	245 °C
>2.5mm	250 °C	245 °C	245 °C

Reference JDEC J-STD-020

Profile Feature	Standard SnPb Solder	Lead (Pb) Free Solder
Preheat and Soak		
• Temperature min. (T_{smin})	100 °C	150 °C
• Temperature max. (T_{smax})	150 °C	200 °C
• Time (T_{smin} to T_{smax}) (t_s)	60-120 Seconds	60-120 Seconds
Average ramp up rate T_{smax} to T_p	3 °C/ Second Max.	3 °C/ Second Max.
Liquidous temperature (T_L)	183 °C	217 °C
Time at liquidous (t_L)	60-150 Seconds	60-150 Seconds
Peak package body temperature (T_p)*	Table 1	Table 2
Time (t_p)** within 5 °C of the specified classification temperature (T_c)	20 Seconds**	30 Seconds**
Average ramp-down rate (T_p to T_{smax})	6 °C/ Second Max.	6 °C/ Second Max.
Time 25 °C to Peak Temperature	6 Minutes Max.	8 Minutes Max.

* Tolerance for peak profile temperature (T_p) is defined as a supplier minimum and a user maximum.
** Tolerance for time at peak profile temperature (t_p) is defined as a supplier minimum and a user maximum.

Life Support Policy: Eaton does not authorize the use of any of its products for use in life support devices or systems without the express written approval of an officer of the Company. Life support systems are devices which support or sustain life, and whose failure to perform, when properly used in accordance with instructions for use provided in the labeling, can be reasonably expected to result in significant injury to the user.

Eaton reserves the right, without notice, to change design or construction of any products and to discontinue or limit distribution of any products. Eaton also reserves the right to change or update, without notice, any technical information contained in this bulletin.

Eaton
Electronics Division
1000 Eaton Boulevard
Cleveland, OH 44122
United States
www.eaton.com/electronics

© 2017 Eaton
All Rights Reserved
Printed in USA
Publication No. 10673 BU-MC17030
May 2017

Eaton is a registered trademark.
All other trademarks are property of their respective owners.